

TUBE INSTALLATION TOOLS



Manufacturer & Exporter of:

Tube Cleaning Equipments such as Flexible Shafts, Brushes, Cutters, Tube Expanders, Construction Equipments Concrete Vibrators, Flexible shaft Grinders & Accessories.

TUBE INSTALLATION TOOLS

✦ SERRATING / GROOVING TOOL 'BST' SERIES FOR GROOVING IN TUBE SHEETS

FEATURES:

- High production tool.
- Ideal for use where 1 tool is needed per bore.
- One piece cryogenically treated tool bit ensures maximum life.
- Its suited for CNC application on account of 1 piece mandrel construction & short design.
- Note: Grooving tools are available for MM bore sizes also, please enquire.

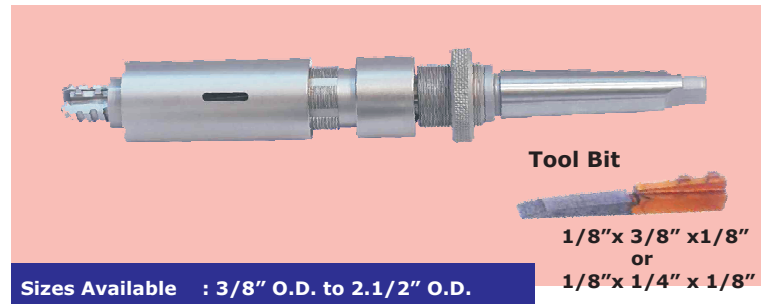

| Tube O. D. | | Tool Model No. | Spare Tool Bits | | |
|------------|-------|----------------|-----------------|------------------|-----------------|
| Inch | Mm | | 1/8"x1/4 x1/8" | 1/8"x 3/8"x 1/8" | Special Spacing |
| 3/8 | 9.53 | BST-375-970 | BST-3703-S | BST-3703 | BST-3703-SPEC |
| 1/2 | 12.70 | BST-500-1270 | BST-5003-S | BST-5003 | BST-5003-SPEC |
| 5/8 | 15.87 | BST-625-1588 | BST-6203-S | BST-6203 | BST-6203-SPEC |
| 3/4 | 19.05 | BST-750-1900 | BST-7503-S | BST-7503 | BST-7503-SPEC |
| 7/8 | 22.22 | BST-875-2220 | BST-7503-S | BST-7503 | BST-7503-SPEC |
| 1 | 25.40 | BST-1000-2540 | BST-7503-S | BST-7503 | BST-7503-SPEC |
| 1.1/4 | 31.75 | BST-1250-3175 | BST-7503-S | BST-7503 | BST-7503-SPEC |
| 1.1/2 | 38.10 | BST-1500-3810 | BST-7503-S | BST-7503 | BST-7503-SPEC |
| 2 | 50.80 | BST-2000-5080 | BST-7503-S | BST-7503 | BST-7503-SPEC |
| 2.1/2 | 63.50 | BST-2500-6350 | BST-7503-S | BST-7503 | BST-7503-SPEC |

Note : Serrating Tools are available for MM bore sizes also. Please enquire.

✦ SERRATING / GROOVING TOOL 'BNW' SERIES

FEATURES:

- Simple to change cutter for different groove shapes.
- Changing of pilot nose & cutter allows one tool to cover a range of hole diameters.
- Location & depth of cut easy to adjust.
- Only light pressure required to cut precision grooves.
- Ready to fit CNC drill machines, lathe and boring machines.
- The life of the cutter extendable by re-shapening.

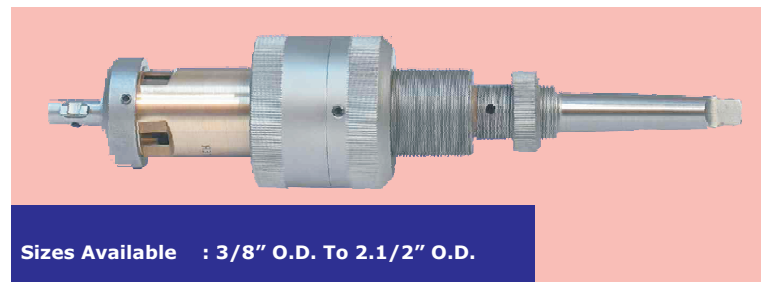

| Bore Range | | Tool Model No. | Pilot Nose Model No. | Circular Form Cutter Model No. | Tool Bit Holder Model No. | Spare Tool Bit Model No. |
|------------|--------|----------------|----------------------|--------------------------------|---------------------------|--------------------------|
| Inch | Mm | | | | | |
| 3/8-1.1/4 | 9-32 | 1BNW-2 MT | 1 BNW - PN | 1BNW - CF | 1BNW - TBH | 1BNW - TB |
| 5/8- 1.3/4 | 16-45 | 2 BNW-3 MT | 2 BNW - PN | 2 BNW - CF | 2 BNW - TBH | 2 BNW - TB |
| 3/4-1.7/8 | 19-48 | 4 BNW-4 MT | 4 BNW - PN | 4 BNW - CF | 4 BNW - TBH | 4 BNW - TB |
| 1.1/2-4 | 38-102 | 6 BNW-5 MT | 6 BNW - PN | 6 BNW - CF | 6 BNW - TBH | 6 BNW - TB |

Note : Specify whether you need Circular Form Cutter (one piece HSS construction) or Tool Bit, when ordering. Refer to operation manual for spare parts list.

TUBE INSTALLATION TOOLS

✦ SERRATING / GROOVING TOOL 'BSGT' SERIES

FEATURES:

- Simple to change cutter for different groove shapes.
- Changing of pilot nose & cutter allows one tool to cover a range of hole diameters.
- Location & depth of cut easy to adjust.
- Only light pressure required to cut precision grooves inside holes or cylinders.
- The life of the cutter extendable by re-shaping.

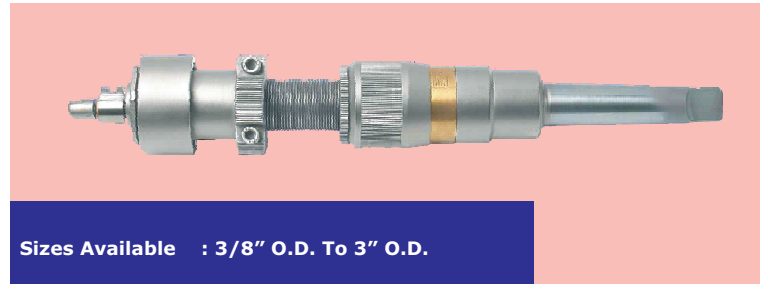

| Bore Range | | Tool Model No. | Pilot Nose / Brushing Model No. | Tool Bits Model No. |
|-------------|-----------|----------------|---------------------------------|---------------------|
| Inch | Mm | | | |
| 0.40 - 0.51 | 10 - 13 | BSGT - 102 | BSGT - 102 - PN | BSGT - 102 - TB |
| 0.50 - 0.63 | 12.7 - 16 | BSGT - 122 | BSGT - 122 - PN | BSGT - 122 - TB |
| 0.63 - 0.79 | 16 - 20 | BSGT - 162 | BSGT - 162 - PN | BSGT - 162 - TB |
| 0.75 - 1.26 | 19 - 32 | BSGT - 193 | BSGT - 193 - PN | BSGT - 193 - TB |
| 1.18 - 2.05 | 30 - 52 | BSGT - 303 | BSGT - 303 - PN | BSGT - 303 - TB |
| 1.97 - 3.07 | 50 - 78 | BSGT - 504 | BSGT - 504 - PN | BSGT - 504 - TB |

PLEASE SUPPLY FOLLOWING INFORMATION WHEN ORDERING GROOVING TOOLS OR SPARE CUTTERS.

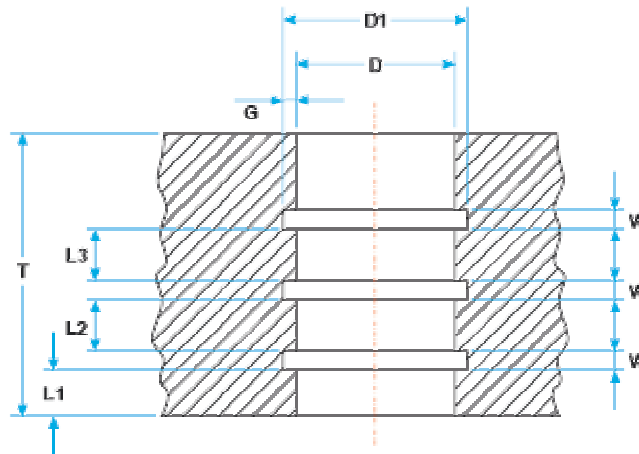

| | | |
|----|--|-------|
| A) | Bore Dia after reaming with Tolerances | D |
| B) | Tube Plate Thickness | T |
| C) | Distance of First Groove | L1 |
| D) | Total Number of Grooves | N |
| E) | Spacing of Grooves | L2,L3 |
| F) | Groove Width | W |
| G) | Diameter of Grooves | D1 |
| H) | Groove undercut Depth | G |

TUBE INSTALLATION TOOLS



✦ TUBE SHEET HOLE REAMER

FEATURES:

- Ideal for heat exchanger and condenser tube sheet reaming.
- High speed steel, cryogenically treated & coated with Titanium, Nitride for long life.
- Reamers are available in MM sizes also.
- For larger diameters, please enquire.



Sizes Available : 3/8" O.D. To 4" O.D.

| Tube O. D. | | Reamer Size To "TEMA" Specification | | Model No | Flute Length | | OAL | | Shank Morse Taper # |
|------------|-------|-------------------------------------|-------|-------------|--------------|-----|-------|-----|---------------------|
| Inch | Mm | Inch | Mm | | Inch | Mm | Inch | Mm | |
| 3/8 | 9.53 | .380 | 9.65 | BRM-095/66 | 2.60 | 66 | 5.70 | 146 | 1 |
| | | | | BRM-095/101 | 3.97 | 101 | 7.12 | 181 | |
| | | | | BRM-095/152 | 5.98 | 152 | 9.13 | 232 | |
| 1 / 2 | 12.70 | .505 | 12.83 | BRM-127/76 | 2.99 | 76 | 6.14 | 156 | 1 |
| | | | | BRM-127/101 | 3.97 | 101 | 7.12 | 181 | |
| | | | | BRM-127/152 | 5.98 | 152 | 9.13 | 232 | |
| 5/8 | 15.87 | .631 | 16.03 | BRM-158/87 | 3.42 | 87 | 7.36 | 187 | 2 |
| | | | | BRM-158/152 | 5.98 | 152 | 9.92 | 252 | |
| | | | | BRM-158/203 | 7.99 | 203 | 11.93 | 303 | |
| - | 16.00 | .636 | 16.16 | BRM-160/152 | 3.42 | 87 | 7.87 | 187 | 2 |
| | | | | BRM-160/203 | 5.98 | 152 | 9.92 | 252 | |
| | | | | BRM-160/254 | 7.99 | 203 | 11.93 | 303 | |
| 3/4 | 19.05 | .758 | 19.25 | BRM-190/100 | 3.90 | 100 | 7.87 | 200 | 2 |
| | | | | BRM-190/152 | 5.98 | 152 | 9.92 | 252 | |
| | | | | BRM-190/203 | 7.99 | 203 | 11.93 | 303 | |
| - | 20.00 | .795 | 20.20 | BRM-200/100 | 3.90 | 100 | 8.15 | 200 | 2 |
| | | | | BRM-200/152 | 5.98 | 152 | 9.92 | 252 | |
| | | | | BRM-200/203 | 7.99 | 203 | 11.93 | 303 | |
| - | 22.00 | .875 | 22.22 | BRM-220/107 | 4.21 | 107 | 8.15 | 207 | 2 |
| | | | | BRM-220/152 | 5.98 | 152 | 9.92 | 252 | |
| | | | | BRM-220/203 | 7.99 | 203 | 11.93 | 303 | |
| 7/8 | 22.22 | .883 | 22.42 | BRM-222/107 | 4.21 | 107 | 8.15 | 207 | 2 |
| | | | | BRM-222/152 | 5.98 | 152 | 9.92 | 252 | |
| | | | | BRM-222/203 | 7.99 | 203 | 11.93 | 303 | |
| - | 25.00 | .994 | 25.25 | BRM-250/115 | 4.53 | 115 | 9.53 | 242 | 3 |
| | | | | BRM-250/203 | 7.99 | 203 | 12.99 | 330 | |
| | | | | BRM-250/254 | 10.00 | 254 | 15.00 | 381 | |
| 1 | 25.40 | 1.010 | 25.65 | BRM-254/115 | 4.53 | 115 | 9.53 | 242 | 3 |
| | | | | BRM-254/203 | 7.99 | 203 | 12.99 | 330 | |
| | | | | BRM-254/254 | 10.00 | 254 | 15.00 | 381 | |
| 1.1/8 | 28.57 | 1.136 | 28.86 | BRM-285/124 | 4.88 | 124 | 9.88 | 251 | 3 |
| | | | | BRM-285/203 | 7.99 | 203 | 12.99 | 330 | |
| | | | | BRM-285/254 | 10.00 | 254 | 15.00 | 381 | |
| 1.1/4 | 31.75 | 1.262 | 32.07 | BRM-317/133 | 5.23 | 133 | 11.53 | 293 | 4 |
| | | | | BRM-317/203 | 7.99 | 203 | 14.29 | 363 | |
| | | | | BRM-317/254 | 10.00 | 254 | 16.30 | 414 | |

TUBE INSTALLATION TOOLS



✦ TUBE END FACER- 'BTEF' SERIES

FEATURES:

- Tool bits are coated with Titanium Nitride to give 3 times the life of conventional tool bits.
- Ideal for quick facing of projecting tube ends in heat exchanger, condensers & boilers.
- One size of tool is suitable for use on multiple tube thickness by interchanging pilot. (TEF-375 is the exception with the tool suitable for one tube ID only.)
- Each tool is supplied with a set of multiple pilots to cover tube thickness.
- Tube end facers for MM sizes of tubes also available. Please enquire.

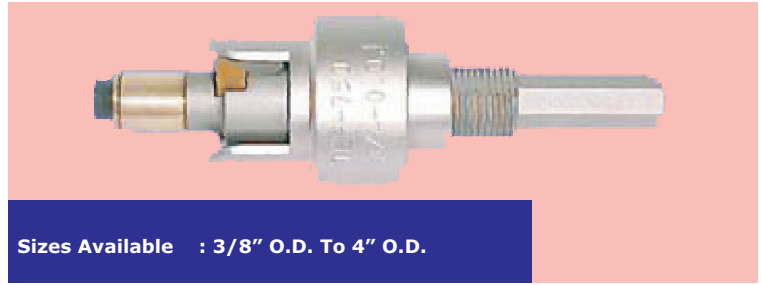

Sizes Available : 3/8" O.D. To 4" O.D.

| Tube O. D. | | Tube Thk. Bwg | Model No. | Spare Tool Bits | |
|------------|-------|---------------|-----------|---|---------------------------------|
| Inch | Mm | | | Non-Ferrous or Carbon Steel Tubes Model No. | Stainless Steel Tubes Model No. |
| 3/8 | 9.53 | 16-22 | BTEF-375 | BTEF-376 | BTEF-376 SS |
| 1/2 | 12.07 | 15-20 | BTEF-500 | BTEF-506 | BTEF-506 SS |
| 5/8 | 15.87 | 14-18 | BTEF-625 | BTEF-626 | BTEF-626 SS |
| 3/4 | 19.05 | 10-18 | BTEF-750 | BTEF-756 | BTEF-756 SS |
| 7/8 | 22.22 | 13-18 | BTEF-875 | BTEF-876 | BTEF-876 SS |
| 1 | 25.40 | 11-18 | BTEF-1000 | BTEF-1006 | BTEF-1006 SS |
| 1.1/8 | 28.57 | 11-18 | BTEF-1125 | BTEF-1126 | BTEF-1126 SS |
| 1.1/4 | 31.75 | 11-18 | BTEF-1250 | BTEF-1256 | BTEF-1256 SS |
| 1.3/8 | 34.92 | 11-18 | BTEF-1375 | BTEF-1376 | BTEF-1376 SS |
| 1.1/2 | 38.10 | 11-18 | BTEF-1500 | BTEF-1506 | BTEF-1506 SS |
| 1.5/8 | 41.27 | 11-18 | BTEF-1625 | BTEF-1626 | BTEF-1626 SS |
| 1.3/4 | 44.45 | 11-18 | BTEF-1750 | BTEF-1756 | BTEF-1756 SS |
| 1.7/8 | 47.62 | 11-18 | BTEF-1875 | BTEF-1876 | BTEF-1876 SS |
| 2 | 50.80 | 11-18 | BTEF-2000 | BTEF-2006 | BTEF-2006 SS |
| 2.1/4 | 57.15 | 11-18 | BTEF-2250 | BTEF-2256 | BTEF-2256 SS |
| 2.1/2 | 63.50 | 11-18 | BTEF-2500 | BTEF-2506 | BTEF-2506 SS |

✦ TUBE END FACER- 'BFB' SERIES

FEATURES:

- High speed production tools.
- Titanium Nitride coated tool bit can be reversed and used. Doubles tool bit life.

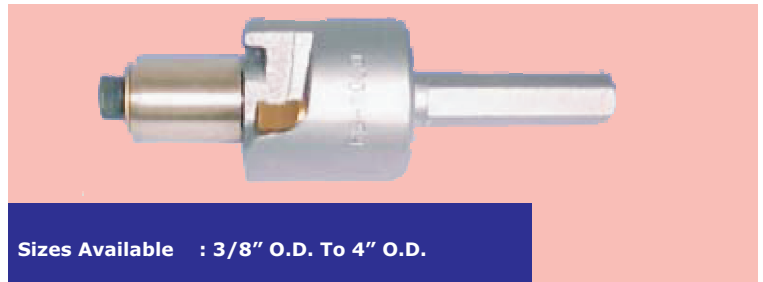

Sizes Available : 3/8" O.D. To 4" O.D.

| Tube O. D. | | Tube Thk. Bwg | Model No. | Spare Tool Bits | |
|------------|-------|---------------|-----------|---|---------------------------------|
| Inch | Mm | | | Non-Ferrous or Carbon Steel Tubes Model No. | Stainless Steel Tubes Model No. |
| 3/8 | 9.53 | 16-22 | BFB-375 | BFB-376 | BFB-376 SS |
| 1/2 | 12.07 | 15-20 | BFB-500 | BFB-506 | BFB-506 SS |
| 5/8 | 15.87 | 14-18 | BFB-625 | BFB-626 | BFB-626 SS |
| 3/4 | 19.05 | 10-18 | BFB-750 | BFB-756 | BFB-756 SS |
| 7/8 | 22.22 | 13-18 | BFB-875 | BFB-876 | BFB-876 SS |
| 1 | 25.40 | 11-18 | BFB-1000 | BFB-1006 | BFB-1006 SS |
| 1.1/8 | 28.57 | 11-18 | BFB-1125 | BFB-1126 | BFB-1126 SS |
| 1.1/4 | 31.75 | 11-18 | BFB-1250 | BFB-1256 | BFB-1256 SS |
| 1.3/8 | 34.92 | 11-18 | BFB-1375 | BFB-1376 | BFB-1376 SS |
| 1.1/2 | 38.10 | 11-18 | BFB-1500 | BFB-1506 | BFB-1506 SS |
| 1.5/8 | 41.27 | 11-18 | BFB-1625 | BFB-1626 | BFB-1626 SS |
| 1.3/4 | 44.45 | 11-18 | BFB-1750 | BFB-1756 | BFB-1756 SS |
| 1.7/8 | 47.62 | 11-18 | BFB-1875 | BFB-1876 | BFB-1876 SS |
| 2 | 50.80 | 11-18 | BFB-2000 | BFB-2006 | BFB-2006 SS |
| 2.1/4 | 57.15 | 11-18 | BFB-2250 | BFB-2256 | BFB-2256 SS |
| 2.1/2 | 63.50 | 11-18 | BFB-2500 | BFB-2506 | BFB-2506 SS |

TUBE INSTALLATION TOOLS

✦ TUBE END FACER- 'BFC' SERIES / WELD REMOVAL TOOL

| Tube O. D. | | Facer Fitted With 3 Tool Bits Model No. | Spare Tool Bits Model No. |
|------------|-------|---|---------------------------|
| Inch | Mm | | |
| 1.1/2 | 38.10 | BFC-1500 | BFC-1500-TB |
| 1.5/8 | 41.27 | BFC-1625 | BFC-1625-TB |
| 1.3/4 | 44.45 | BFC-1750 | BFC-1750-TB |
| 1.7/8 | 47.62 | BFC-1875 | BFC-1875-TB |
| 2 | 50.80 | BFC-2000 | BFC-2000-TB |
| 2.1/4 | 57.15 | BFC-2250 | BFC-2250-TB |
| 2.1/2 | 63.50 | BFC-2500 | BFC-2500-TB |
| 2.3/4 | 69.85 | BFC-2750 | BFC-2750-TB |
| 3 | 76.20 | BFC-3200 | BFC-3200-TB |
| 3.1/4 | 82.55 | BFC-3250 | BFC-3250-TB |
| 3.1/2 | 88.90 | BFC-3500 | BFC-3500-TB |
| 3.3/4 | 95.25 | BFC-3750 | BFC-3750-TB |
| 4 | 101.6 | BFC-4000 | BFC-4000-TB |

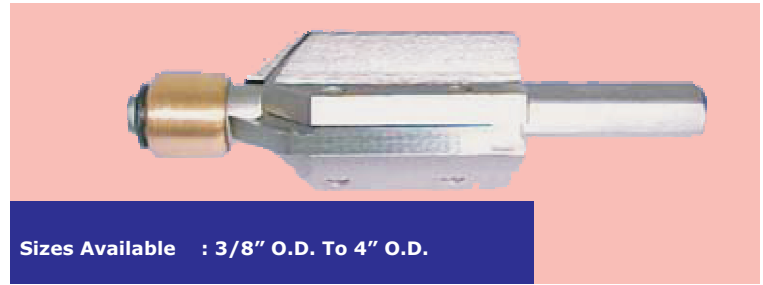

Sizes Available : 3/8" O.D. To 4" O.D.

FEATURES:

- Tool uses 3 cutting blades which can be configured for tube end facing or weld removal as step in the removal of welded tubes from the tube sheet.
- Tool fitted with MT shank for use with standard air or electric drills.
- Cutting blades are titanium Nitride coated to give 3 times the life of conventional cutting blades.
- Ideally suited for work on larger diameter boiler tubes .
- Tools available for MM sizes of tubes also. Please enquire

✦ FLARING TOOL:

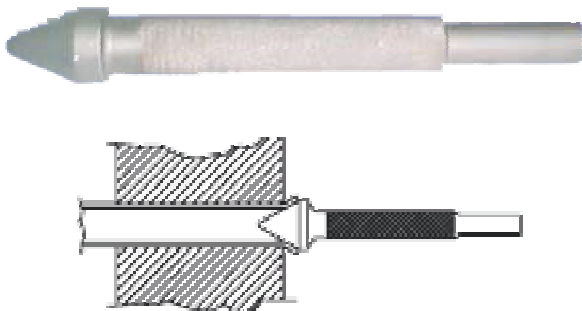

✦ BEADING TOOL

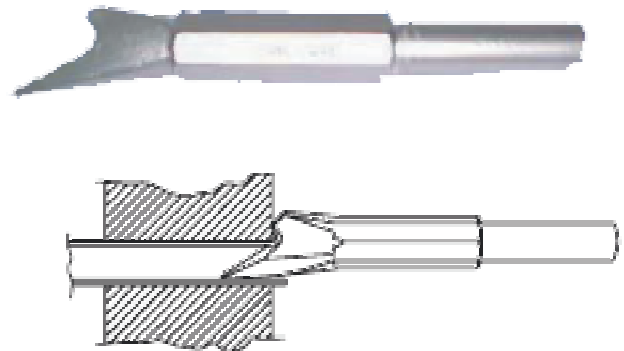

| Tube O. D. | | Tube Thk. bwg. | Model No. |
|------------|-------|----------------|-----------|
| Inch | Mm | | |
| 1/2 | 12.70 | 16-22 | BFT-1 |
| | | 14-15 | BFT-2 |
| 5/8 | 15.87 | 16-22 | BFT-3 |
| | | 14-15 | BFT-4 |
| 3/4 | 19.05 | 16-22 | BFT-5 |
| | | 14-15 | BFT-6 |
| 7/8 | 22.22 | 16-22 | BFT-7 |
| | | 12-15 | BFT-8 |
| 1 | 25.40 | 16-22 | BFT-9 |
| | | 12-15 | BFT-10 |
| 1.1/8 | 28.57 | 16-22 | BFT-11 |
| | | 8-14 | BFT-12 |
| 1.1/4 | 31.75 | 15-22 | BFT-13 |
| | | 8-14 | BFT-14 |
| 1.3/8 | 34.92 | 15-22 | BFT-15 |
| | | 8-14 | BFT-16 |
| 1.1/2 | 38.10 | 15-22 | BFT-17 |

Note : Fitted with Type 1 round shank for use with standard pneumatic chipping hammer.
Other shanks on request.

| Tube O. D. | | Tube Thk. bwg. | Model No. |
|------------|-------|----------------|-----------|
| Inch | Mm | | |
| 1/2 | 12.70 | 16-17 | BBDT-1 |
| | | 18-19 | BBDT-2 |
| | | 20-22 | BBDT-3 |
| 5/8 | 15.87 | 16-17 | BBDT-4 |
| | | 18-19 | BBDT-5 |
| | | 20-22 | BBDT-6 |
| 3/4 | 19.05 | 16-17 | BBDT-7 |
| | | 18-19 | BBDT-8 |
| | | 20-22 | BBDT-9 |
| 7/8 | 22.22 | 16-17 | BBDT-10 |
| | | 18-19 | BBDT-11 |
| | | 20-22 | BBDT-12 |
| 1 | 25.40 | 16-17 | BBDT-13 |
| | | 18-19 | BBDT-14 |
| | | 20-22 | BBDT-15 |

Note : Fitted with Type 1 round shank for use with standard pneumatic chipping hammer.
Other shanks on request.

TUBE INSTALLATION TOOLS



BELLING TOOL

- In many condensers the inlet end of tubes are required to be seated into the sheet (Not projecting). The contour is a "Bell End" or "Trumpet Mouth" of special shape.

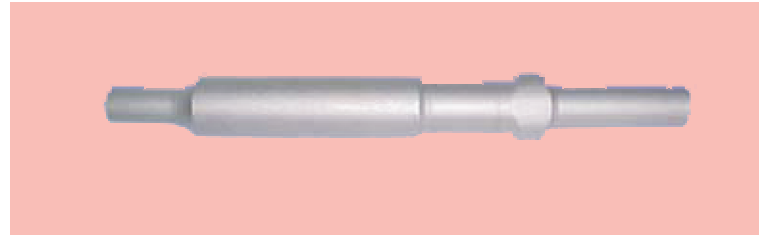

TUBE SHEET HOLE RADIUS CUTTER

- MM sizes and cutter with other radii are also available. Please enquire.
- High speed steel tool used in preparing tube sheets to suit the flaring or beading of tube ends outside of or flush with the tube sheet.

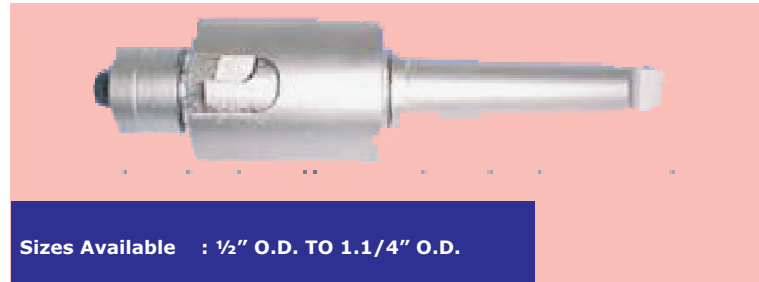

TUBE GUIDE

- To pilot tubes through the tube sheet & baffle plates during tube insertion.

NOTE: For intermediate or larger size please contact us.

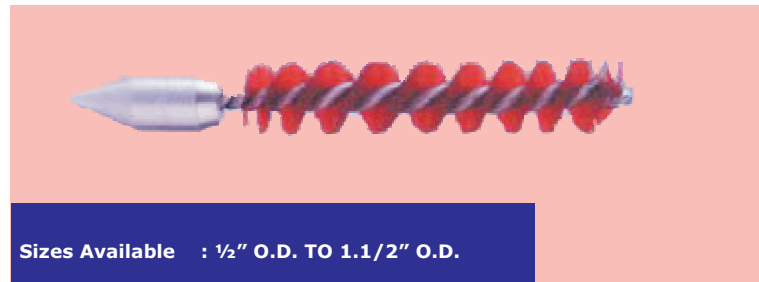

TUBE SHEET HOLE BRUSH

- To clean tube sheet bores, prior to tube installation
- Can be used with any standard pneumatic or electric drill

NOTE: For intermediate or larger size please contact us.

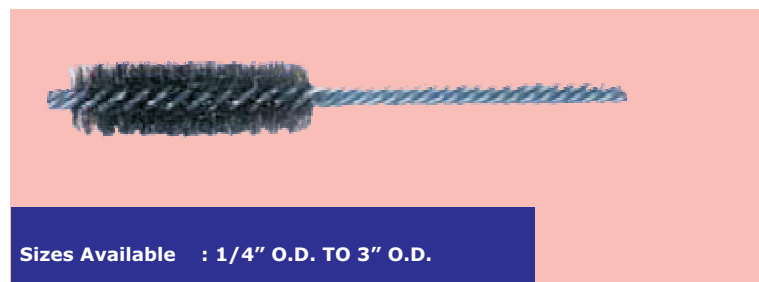

NOTE: FOR MODEL NOS OF ABOVE TOOLS PLEASE CONTACT US.

BHARTIYA INDUSTRIES

WORKS: PLOT NO. 268, DIGVIJAY INDUSTRIAL ESTATE NO.2.
UPAVAN, POKHARAN ROAD NO.1, THANE (W) M.S. INDIA - 400603.
OFFICE: G-201, USHA COMPLEX, KHANDELWAL MARG, BHANDUP (W.), MUMBAI -400078, INDIA
PH.: +91-22-2585 4509, 6505 6400, 2566 6421 FAX: +91-22-2585 4509.
Website: www.bharatflex.com, www.bharatiyaindustries.com, E-mail : bharatflex@yahoo.com

Authorised Dealer